

High Efficiency, High Quality PV Module

125' CELL MONO 100Wp



MODULE CHARACTERISTICS

- ◆ Solar Cell: High efficiency crystalline solar cell. Even if under the weak light, the solar module can produce maximum power output.
- ◆ Tempered glass: Anti-reflecting coating and high transmission rate glass increase the power output and mechanical strength of solar module.
- ◆ EVA and TPT: Using high quality EVA and TPT to prevent destroying and water.
- ◆ Al frame: Without screw, corner connection. 6 holes on the frame can be installed easily.
- ◆ Junction box: Multi function junction box with water proof and bypass diode, which protects the module from burning caused by hot-spot effect because of shading
- ◆ High reliability with guaranteed $\pm 3\%$ power output tolerance, ensuring return on investment
- ◆ Withstands high wind-pressure and snow load (passed IEC 5400Pa mechanical loading test), and extreme temperature variations. Resisting moisture and etching effectively, not effect by geology.
- ◆ Rigorous quality control meeting the highest international standards ISO 9001:2000 (Quality Management System) and ISO 14001:2004 (Environmental Management System) certified factories manufacturing world class products.
- ◆ 5-year product quality guarantee and 25-year power output transferable guarantee. Long lifetime: ≥ 25 years; Less power decrease.

ELECTRICAL PARAMETERS

Model No.	BL-SP100M-B
Maximum Power at STC (Pmax)	100 Wp
Open Circuit Voltage (Voc)	22.40 V
Short Circuit Current (Isc)	5.90 A
Optimum Operating Voltage (Vmp)	18.50 V
Optimum Operating Current (Imp)	5.41 A
Cell Efficiency	19.10 %
Power Tolerance	0~+3 %
Operating Temperature	-40°C to +85°C
Maximum System Voltage	1000V DC

SOLAR PHOTOVOLTAIC MODULE

MODEL: BL-SP100M-B (all in black)

COMPLY WITH ISO9001:2008

MECHANICAL PARAMETERS

Cell Type	Mono-crystalline silicon 125x125mm
No. of Cells and Connection	36 (4x9)
Dimensions of Module	1180x550x30mm
Weight	6.9 kg
Area	0.64 m ²
Cable & Connector Type	4mm ² x900mm with MC4
Junction Box Type	IP 68 Pass TUV
Front Class	3.2mm tempered glass
Frame	Anodized Aluminium Alloy
Max.Series Fuse Rating	15A
Surface Max.Load Capacity	2400-5400 Pa
Max. Hail Load	23m/s, 7.53g
Standard Test Condition	AM1.5 1000W/m ² 25 ±2°C

I-V CURVE

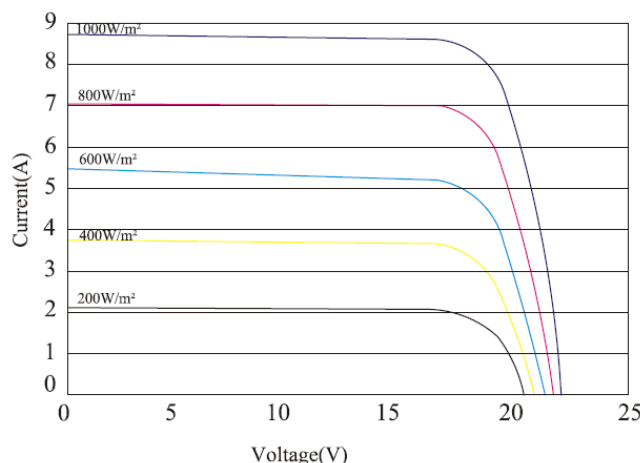

TEMPERATURE COEFFICIENTS

NOCT	45±2°C
Peak Power Tk(Wp)	-0.45 %/°C
Open Circuit Voltage Tk(Voc)	-0.34 %/°C
Short Circuit Current Tk(Isc)	0.05 %/°C

PRODUCT GARANTEE

Product Quality	5 years
Power Output	Not less than 90% in 10 years Not less than 80% in 25 years
Certificate	ISO9001, IEC61215&61730, CE

PACKING AND LOADING

Packing Way	Carton or Wooden box
1*20' Container	882pcs
1*40GP Container	1802pcs

MECHANICAL DIMENSIONS

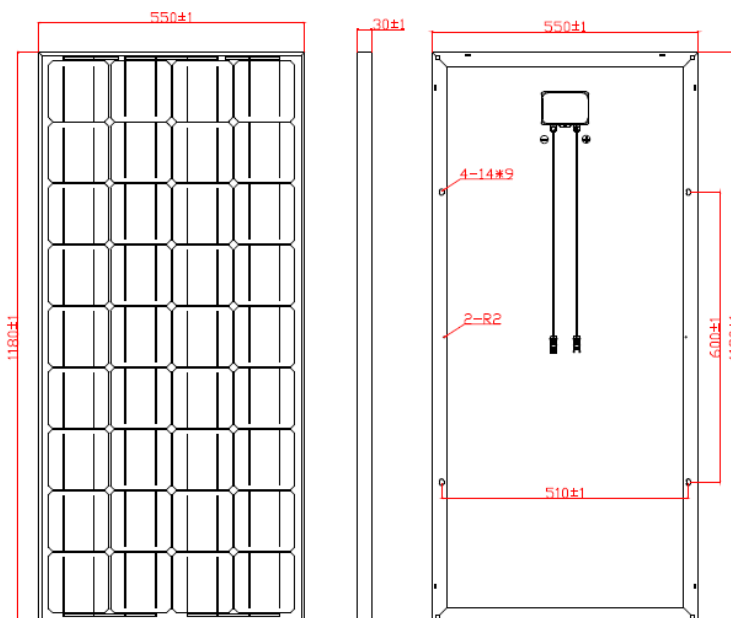

SOLAR POWER SYSTEM SUPPLIER