

## High Efficiency, High Quality PV Module

### 182' CELL MONO 130Wp

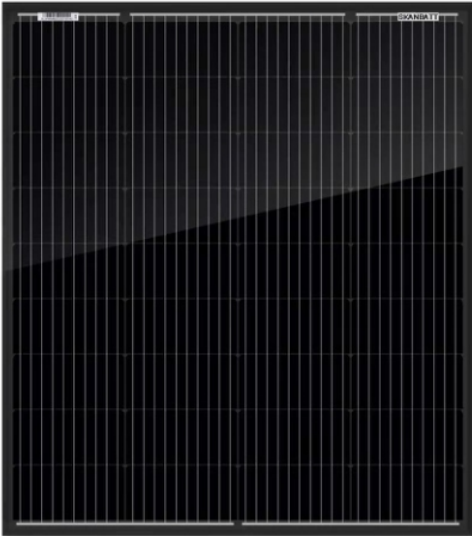

### MODULE CHARACTERISTICS

- ◆ Solar Cell: High efficiency crystalline solar cell. Even if under the weak light, the solar module can produce maximum power output.
- ◆ Tempered glass: Anti-reflecting coating and high transmission rate glass increase the power output and mechanical strength of solar module.
- ◆ EVA and TPT: Using high quality EVA and TPT to prevent destroying and water.
- ◆ Al frame: Without screw, corner connection. 6 holes on the frame can be installed easily.
- ◆ Junction box: Multi function junction box with water proof and bypass diode, which protects the module from burning caused by hot-spot effect because of shading
- ◆ High reliability with guaranteed 0~+3% power output tolerance, ensuring return on investment
- ◆ Withstands high wind-pressure and snow load (passed IEC 5400Pa mechanical loading test), and extreme temperature variations. Resisting moisture and etching effectively, not effect by geology.
- ◆ Rigorous quality control meeting the highest international standards ISO 9001:2000 (Quality Management System) and ISO 14001:2004 (Environmental Management System) certified factories manufacturing world class products.
- ◆ 10-year product quality guarantee and 25-year power output transferable guarantee. Long lifetime: ≥25 years; Less power decrease.

### ELECTRICAL PARAMETERS

Model No.	BL-SP130M-B
Maximum Power at STC (Pmax)	130 Wp
Open Circuit Voltage (Voc)	24.58 V
Short Circuit Current (Isc)	6.44 A
Optimum Operating Voltage (Vmp)	21.25 V
Optimum Operating Current (Imp)	6.12 A
Module Efficiency	19.20 %
Power Tolerance	0~+3 %
Operating Temperature	-40°C to +85°C
Maximum System Voltage	700V DC

# SOLAR PHOTOVOLTAIC MODULE

MODEL: BL-SP130M-B (all in black with 10BB 182 cells)

# SKANBATT

COMPLY WITH ISO9001:2008

## MECHANICAL PARAMETERS

Cell Type	Mono-crystalline silicon 182x91mm
No. of Cells and Connection	36 (4x9)
Dimensions of Module	885x765x30mm
Weight	7.10 kg
Area	0.677 m <sup>2</sup>
Cable & Connector Type	4.0mm <sup>2</sup> x500mm with MC4
Junction Box Type	IP 68 Pass TUV
Front Class	3.2mm tempered glass
Frame	Anodized Aluminium Alloy
Max.Series Fuse Rating	10 A
Surface Max.Load Capacity	2400-5400 Pa
Max. Hail Load	23m/s, 7.53g
Standard Test Condition	AM1.5 1000W/m <sup>2</sup> 25 ±2°C

## I-V CURVE

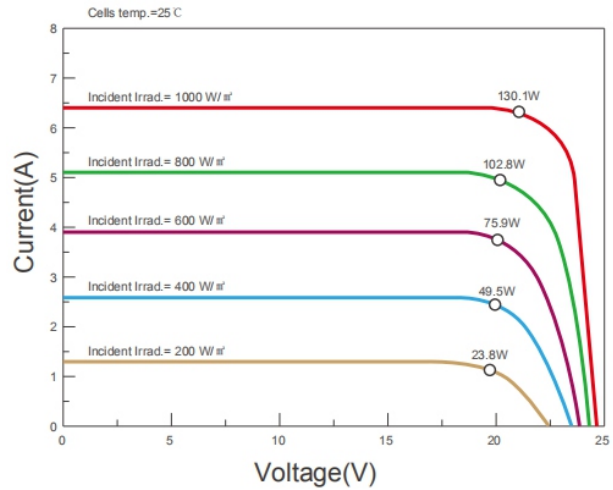

## PRODUCT GARANTEE

Product Quality	10 years
Power Output	Not less than 90% in 10 years Not less than 80% in 25 years
Certificate	ISO9001, IEC61215&61730, CE

## TEMPERATURE COEFFICIENTS

NOCT	45±2°C
Peak Power Tk(Wp)	-0.45 %/°C
Open Circuit Voltage Tk(Voc)	-0.34 %/°C
Short Circuit Current Tk(Isc)	0.05 %/°C

## PACKING AND LOADING

Packing Way	Carton or Wooden box
Pallet Dimensions	935 x 1100 x 885mm
Weight & quantity per pallet	290KG & 36pcs

## MECHANICAL DIMENSIONS

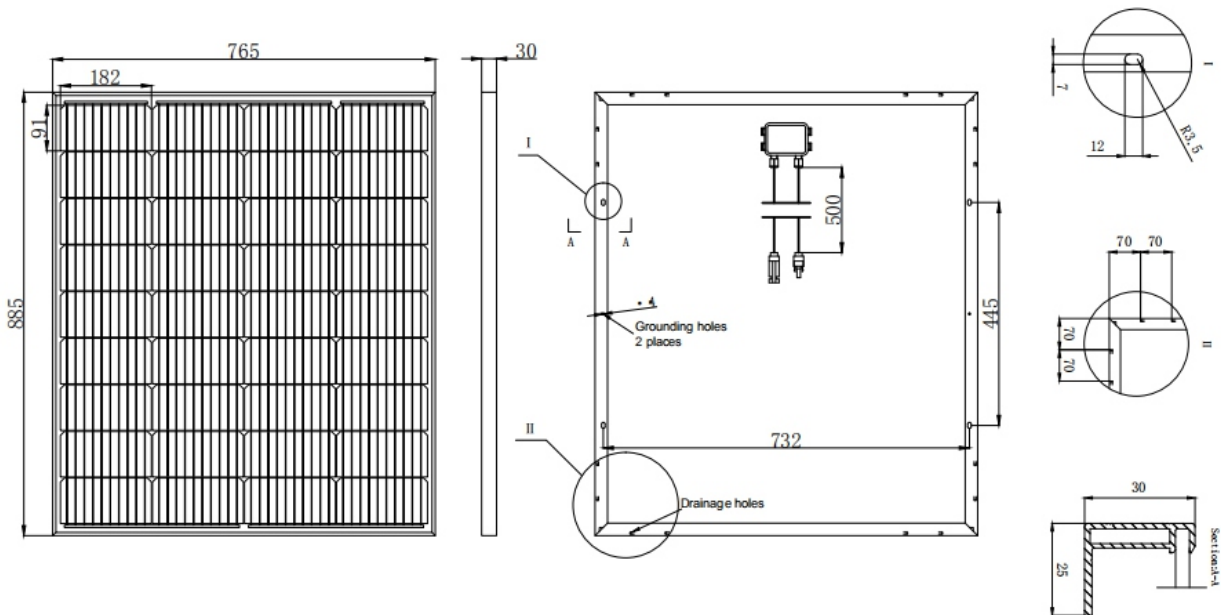

SOLAR POWER SYSTEM SUPPLIER

